

SERIES 380 4 Drop Breathing Air Assembly

380-4SA446 Model
Port Size: 1/2



Model Shown: 380-4SA446

Master Pneumatic's breathing air assembly is designed to provide breathing air for up to 4 workers.

The general purpose filter in this assembly removes gross contaminants while the coalescing filter removes oil mists, aerosols and minute particles. The adsorbing filter effectively eliminates odors from freons, alcohols, esters, keytones and up to 99 percent of most hydrocarbons. The CO monitor is designed to detect and alert user to presence of CO if the level is 10 ppm or greater as stated in OSHA title 29 section 1910.134(D)(1)&(2) ANSI/CGA standard G-7.1

SPECIFICATIONS

Ambient/Media Temperature:

Plastic Bowl, float drain: 40° to 120°F (4° to 49°C).

Body: Die-cast zinc.

Bowl: 9-Ounce (270-ml) capacity polycarbonate plastic with nylon shatterguard.

Bowl Drains:

Filter and Coalescing Filter: Internal float drain. By removing the adjustment knob a 3/16" (5mm) flexible tube can be connected to drain effluents.

Adsorber Filter: Manual drain.

Cap Color: Blue.

Differential Pressure Gauge: Included.

Elements:

Filter: 5- μ m-rated polyethylene.

Coalescing: 0.3- μ m-rated borosilicate-glass-fiber.

Adsorbing: Activated carbon with urethane seals.

Fluid Media: Compressed air.

Operating Pressure:

Plastic Bowl & Float drain: 80-150 psig (5.5-10.3 bar).

Seals: Nitrile

Quick Disconnect: Hansen style

Flow: Up to 60 SCFM

GENERAL

- ◆ Modular or inline mounting, front mounted modular clamping design with encapsulated screws.
- ◆ 1/2" NPTF port threads
- ◆ Polycarbonate plastic bowl with steel shatterguard - Unique to Series 380.
- ◆ This Breathing Air Assembly can allow end users to achieve "grade D" breathing air as defined by the Compressed Gas Association's commodity specification: G-7.1 (www.cganet.com). Does not remove carbon monoxide or convert CO to CO², or remove other toxic gases.
- ◆ Designed to flow at max of 15 scfm per drop.

GENERAL PURPOSE FILTER

- ◆ Designed to remove particulate material to 5 micron from the airstream to protect downstream equipment. Superior removal of free water up to 98% efficiency

COALESCING FILTER

- ◆ Designed to remove particulate material 99.98% of free oils and solid contaminants 0.3 microns and larger.
- ◆ Removal of effluents via float drains. Coalescent elements are absolute rated.
- ◆ Standard differential pressure gauge to indicate when filter element needs changing.

ADSORBING FILTER

- ◆ Designed to remove oil vapor that cannot be removed by a coalescent filter. Also removes odors and tastes.
- ◆ Filter cartridge contains activated carbon.

THIS UNIT DOES NOT REMOVE CARBON MONOXIDE OR CONVERT CO TO CO², OR REMOVE OTHER TOXIC GASES.

⚠ DANGER

ENVIRONMENT MUST NOT CONTAIN COMBUSTABLE GAS OR VAPORS.

DIMENSIONS inches (mm)

Bowl	A	B	C	Depth	Weight lb (kg)
Standard	21.5 (547)	8.5 (217)	9.5 (241)	4.26 (108.3)	15.85 (7.19)

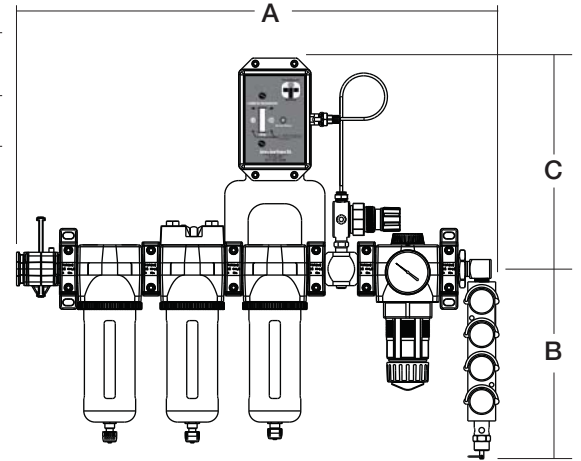

Plastic Bowls

CALIBRATION KIT - Required prior to operation:

- Calibration Regulator for MMP CO Monitor 118-137
- Calibration Gas Kit..... 118-138
- Bottles of 10PPM Carbon Monoxide, 1 bottle of Impurity
- Free Air and CGA600 Connection.
- (If Units are checked monthly, this kit should last for 2 years)*

REPLACEMENT ELEMENT KITS:

- Filter Elements:**
- 5-µm Polyethylene A115-106PE5
- Coalescing Elements:**
- 0.3 µm Borosilicate glass A115-117
- Adsorbing Elements:**
- Activated carbon A115-117E9

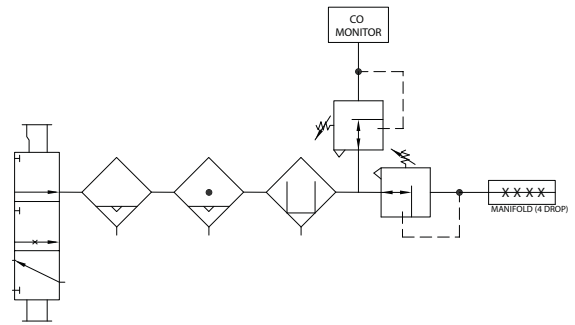

ISO Clean Air Package Symbol

CONNECTORS and OPTIONAL MONITOR ACCESSORIES:

- Coupler socket - 1/4" quick disconnect male, steel 118-131
- Coupler plug - 1/4" x 1/4" NPTF industrial interchange male, steel 118-139
- Remote horn, strobe and stand - 100 db @ 10 foot 118-140
- 25 foot cable for use with 118-140 remote horn, etc 118-141
- 50 foot cable for use with 118-140 remote horn, etc 118-142
- Remote horn with 25 foot attached cable - 100 db @ 10 foot 118-146
- Remote horn with 50 foot attached cable - 100 db @ 10 foot 118-147
- Remote relay box (no horn, no cable) 118-143
- Remote relay box with 25 foot cable (no horn) 118-149
- Remote small horn (no cable) - 100 db @ 10 inches 118-148
- 25 foot cable for use with 118-148 remote small horn 118-144
- 50 foot cable for use with 118-148 remote small horn 118-145