



# R100 Service Parts and Maintenance

MASTER PNEUMATIC, INC.

6701-18 Mile Rd. | Sterling Heights, MI 48314 | Phone: (586) 254-1000 | Fax: (586) 254-6055 | Email: mp@masterpneumatic.com

JM 11-27-01  
REV: 06-09-11  
ECN (4704)  
OLD: A435

## Replacement Parts & Kits

**THANK YOU!**

You have just purchased a quality Regulator from Master Pneumatic.

With care in it's installation and maintenance, you can expect it to have a long and economical service life. Before you go any further, please take a few minutes to look over this information, then save it for future reference and for the useful service information it contains.

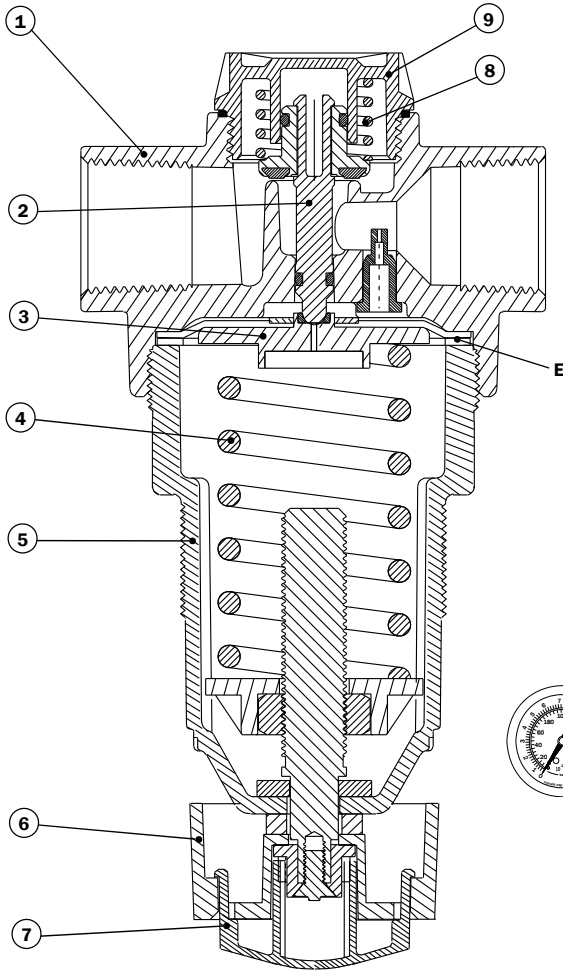

KEY	DESCRIPTION	R100-2	R100-3	R100-4	R100-6
1	Head Assembly	KAM37-01-2	KAM37-01-3	KAM37-01-4	KAM37-01-6
2	Valve Assembly	A35-10M	A35-10M	A35-10M	A35-10M
3	Diaphragm Assembly	A37-03	A37-03	A37-03	A37-03
4	Main Spring	37-153	37-153	37-153	37-153
5	Dome Assembly	A37-02P	A37-02P	A37-02P	A37-02P
6	Knob Adjustment Kit	KA37-62	KA37-62	KA37-62	KA37-62
7	Adjusting Key	37-63	37-63	37-63	37-63
8	Valve Spring (qty 5)	KV35-11M	KV35-11M	KV35-11M	KV35-11M
9	Cap Kit	K37-57	K37-57	K37-57	K37-57



PART NUMBER	DIAL FACE	CALIBRATIONS	MOUNTING
200-BDD	2" (5.1 cm)	0-200 PSI (0-14 BAR)	1/4"-18 NPTF
60BDD		0-60 PSI (0-4 BAR)	CENTER BACK
200-SDDX		0-200 PSI (0-14 BAR)	1/4"-18 NPT SIDE

KIT NUMBER	DESCRIPTION
K37-71	Panel mount nut and wall bracket
KA37-68	Gauge port wall bracket
KA37-68L	Gauge port extended wall bracket
K30-08	Top mount wall bracket

## Installation Procedures - Regulator

### INSTALLATION:

Shut off or lockout air pressure. Install the regulator as near as possible to the device it is to serve, following the direction of the arrow on regulator head for air flow. Regulators should be installed upstream of any lubricator or valves in the airline. Installing downstream of a conventional M/P filter with standard 5 micrometer filter element will insure a supply of clean air. Install a pressure gauge or plug the gauge ports.

### ADJUSTMENTS:

To acquire the desired air line pressure, turn the adjustment knob (#6) counter-clockwise lowering the line pressure below the required P.S.I.. Then increase pressure by turning the adjustment knob (#6) clockwise until the preferred P.S.I. is acquired. Pull adjusting key (#7) down for non-adjustment mode. Remove key entirely for tamper resistance.

### MAINTENANCE:

Shut-off or lockout air supply. Reduce spring load to zero by turning the adjusting knob (#6) counter-clockwise. Remove the dome (#5) by unscrewing it counter-clockwise. The diaphragm assembly (#3) can now be removed. The valve assembly (#2) can be removed by unscrewing the cap (#9). Clean the parts with warm water and soap. Lubricate all O-rings with Lithium grease. If the regulator cannot be repaired by cleaning, the operating parts should be replaced. (See parts list above) Make sure all seals are correctly located when reassembling regulator. The clamping washer (E) must be between the diaphragm and the dome. The dome should be tightened with a strap wrench, to approximately 190-210 in-lbs. Torque Cap (#9) to 55-65 in-lbs.



# R100 Service Parts and Maintenance

MASTER PNEUMATIC, INC.

6701-18 Mile Rd. | Sterling Heights, MI 48314 | Phone: (586) 254-1000 | Fax: (586) 254-6055 | Email: mp@masterpneumatic.com

## Dimensional Specifications

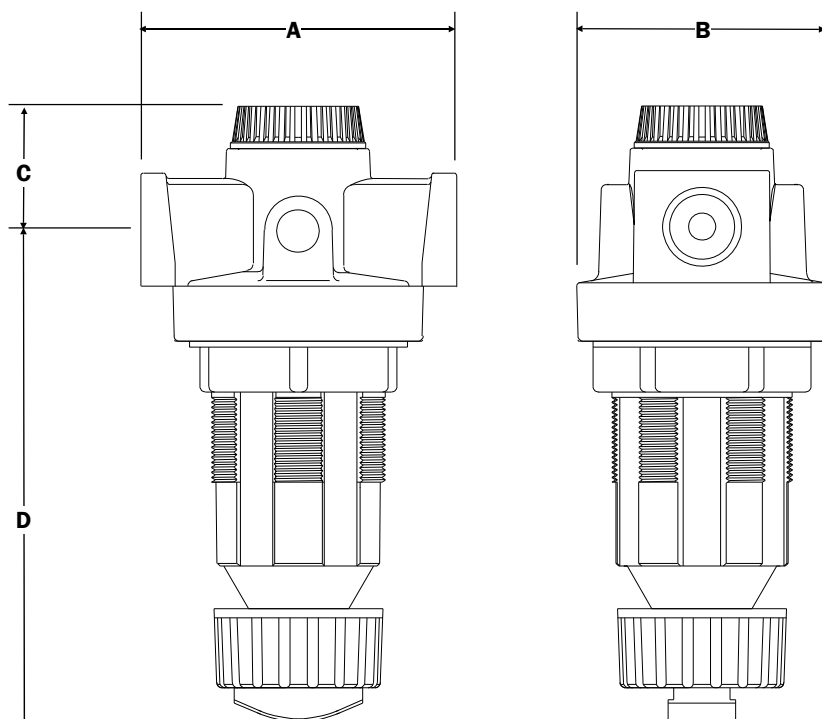

KEY	R100-2	R100-3
A	3-1/2 (8.89 cm)	3-1/2 (8.89 cm)
B	2-25/32 (7.06 cm)	2-25/32 (7.06 cm)
C	1-5/16 (3.33 cm)	1-5/16 (3.33 cm)
D	5-3/4 (14.6 cm)	5-3/4 (14.6 cm)

KEY	R100-4	R100-6
A	3-1/2 (8.89 cm)	3-1/2 (8.89 cm)
B	2-25/32 (7.06 cm)	2-25/32 (7.06 cm)
C	1-5/16 (3.33 cm)	1-5/16 (3.33 cm)
D	5-3/4 (14.6 cm)	5-3/4 (14.6 cm)

## General Specifications

**MAXIMUM INLET PRESSURE:** 300 psig (21 bar)

**MAXIMUM TEMPERATURE:** 175 Degree F. (79 Degree C.)

### ADJUSTING RANGE:

**Standard Range:** 0-125 psig (0-8.6 bar)

**'H' Option Spring:** 0-175 psig (0-12.1 bar)

**'L' Option Spring:** 0-50 psig (0-3.3 bar)

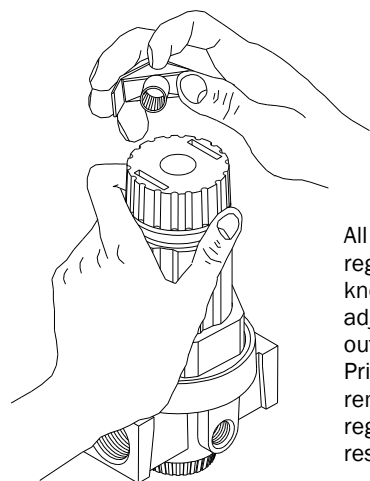

All vanguard high capacity series regulators are standard with locking knobs. A "key" is pushed in to adjust the regulator. When pulled out, the adjusting knob spins freely. Pried up on one end, the key is removed as shown and the regulator setting is tamper resistant.

### AVAILABLE OPTIONS

- A** Non-relieving
- E** Internal reverse bypass - Quick exhaust
- G** 0-200 psig gauge (0-13.2 bar)
- H** High pressure spring 0-175 psi (0-12.1 bar)
- JJ** Remove adjusting key
- M** Pressure limit > 50 psi (> 3.3 bar)
- ML** Pressure limit < 50 psi (< 3.3 bar)
- L** Low adjusting spring 0-50 psi (0-3.3 bar)
- P** Panel mount nut
- T** Tee Handle
- W** BSP British (Whitworth) threads