



PR100 Service Parts and Maintenance

MASTER PNEUMATIC - DETROIT, INC.

6701 -18 Mile Rd. | Sterling Heights, MI 48314 | Phone: (586) 254-1000 | Fax: (586) 254-6055 | Email: mp@masterpneumatic.com

Replacement Parts & Kits

THANK YOU!

You have just purchased a quality Pilot Regulator from Master Pneumatic.

With care in its installation and maintenance, you can expect it to have a long and economical service life. Before you go any further, please take a few minutes to look over this information, then save it for future reference and for the useful service information it contains.

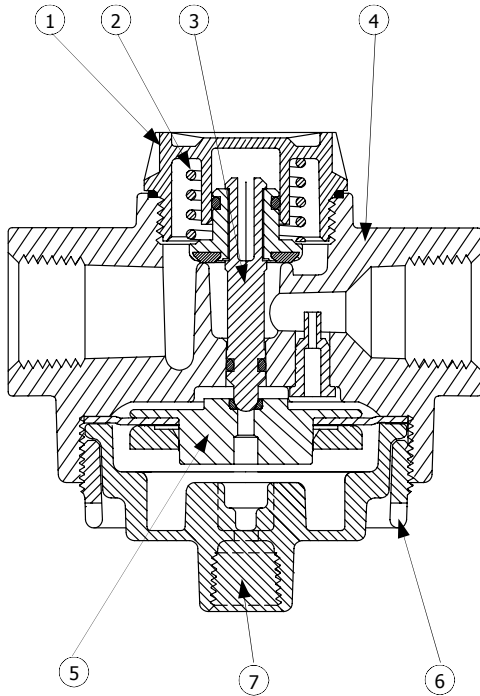

KEY	DESCRIPTION	PR100-2	PR100-3	PR100-4	PR100-6
1	Cap Kit	K37-57	SAME	SAME	SAME
2	Spring Kit	KV35-11M	SAME	SAME	SAME
3	Valve Kit	KA35-10M	SAME	SAME	SAME
4	Head Kit	KA37-01-1/4	KA37-01-3/8	KA37-01-1/2	KA37-01-3/4
5	Diaphragm Kit	KA37-108	SAME	SAME	SAME
6	Retaining Ring	37-249	SAME	SAME	SAME
7	Dome	37-250	SAME	SAME	SAME

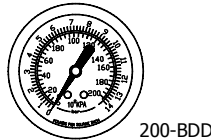
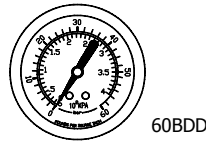

PART NUMBER	DIAL FACE	CALIBRATIONS	MOUNTING
200-BDD	2" (5.1 cm)	0-200 PSI (0-14 BAR)	1/4"-18 NPT
60BDD		0-60 PSI (0-4 BAR)	CENTER BACK
200-SDDX		0-200 PSI (0-14 BAR)	1/4"-18 NPT SIDE

KIT NUMBER	DESCRIPTION
KA37-68	Gauge port wall bracket
KA37-68L	Gauge port extended wall bracket
K30-08	Top mount wall bracket

Installation Procedures

INSTALLATION AND OPERATION

Install the unit as near as possible to the device it is to serve. Use the size regulator that corresponds to the maximum flow required. Filters should be installed immediately ahead of the regulator to insure a clean supply of air. The air pressure is regulated by force created due to the pilot pressure (supplied by remote regulator) acting against the diaphragm, which opens and closes the supply valve to maintain the set pressure with flow through the regulator. Overpressure is relieved when pressure on the top on the diaphragm exceeds the pilot pressure acting on the bottom of the diaphragm.

MAINTENANCE

If the air supply is kept clean, the regulator should provide long periods of uninterrupted service. Erratic operation or loss of regulation is usually due to dirt or a leaking seal.

REPAIR INSTRUCTIONS

Shut off air supply and exhaust trapped air. The supply valve can be removed by unscrewing the valve cap. Clean the valve seat with soap and water to remove any dirt. The diaphragm must be pre-loaded after assembly for proper operation. Because of this, it is not recommended that the dome be removed. If the regulator cannot be repaired by cleaning the valve, and the pilot supply regulator is functioning properly, the regulator should be returned to the factory for repairs.



PR100 Service Parts and Maintenance

MASTER PNEUMATIC - DETROIT, INC.

6701 -18 Mile Rd. | Sterling Heights, MI 48314 | Phone: (586) 254-1000 | Fax: (586) 254-6055 | Email: mp@masterpneumatic.com

Dimensional Specifications

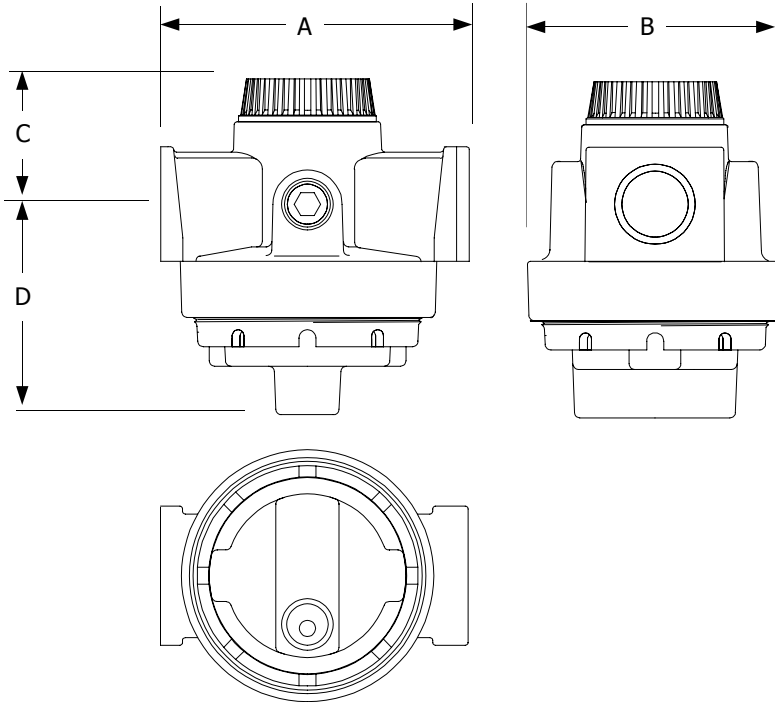

KEY	PR100-2	PR100-3
A	3.5 (89 mm)	3.5 (89 mm)
B	2.06 (0.92 mm)	2.06 (0.92 mm)
C	1.3 (33 mm)	1.3 (33 mm)
D	4.2 (106 mm)	4.2 (106 mm)

KEY	PR100-4	PR100-6
A	3.5 (89 mm)	3.5 (89 mm)
B	2.06 (0.92 mm)	2.06 (0.92 mm)
C	1.3 (33 mm)	1.3 (33 mm)
D	4.2 (106 mm)	4.2 (106 mm)

General Specifications

MAXIMUM INLET PRESSURE: 300 psig (21 bar)

MAXIMUM TEMPERATURE: 175 Degree F. (79 Degree C.)

AVAILABLE OPTIONS

- A Non-relieving
- G 0-200 psig gauge (0-13.2 bar)
- W BSP British (Whitworth) threads