



BFCD201 Installation and Maintenance

MASTER PNEUMATIC - DETROIT, INC.

6701 -18 Mile Rd. | Sterling Heights, MI 48314 | Phone: (586) 254-1000 | Fax: (586) 254-6055 | Email: mp@masterpneumatic.com

PRODUCT NUMBERS:

BFCD201-6
BFCD201-8

THANK YOU!

You have just purchased a quality Coalescent Filter from Master Pneumatic.

With care in its installation and maintenance, you can expect it to have a long and economical service life. Before you go any further, please take a few minutes to look over this information, then save it for future reference and for the useful service information it contains.

Installation & Operation Procedures

NOTE: Read Warning Stuffer STU-A019 included in box with product before proceeding.

INSTALLATION:

1. Depressurize and lockout air pressure.
2. Upstream pipes must be free of excessive dirt and liquids.
3. A conventional M/P Filter with standard 5 micron filter element should be installed immediately ahead of Coalescing Filters to maximize the life of the coalescing element.
4. Install the Coalescent Filter as near as possible to the device it is to serve.
5. Install the Coalescent Filter so that air flows from inlet to outlet as shown on the head.
6. The Coalescent Filter must be installed vertically with drain mechanism at the bottom.
7. Coalescent Filters should be installed upstream of any Regulators or Lubricators in the airline.

OPERATION:

1. For Manual Drain models: Periodically drain to discharge accumulated liquids by turning Draincock clockwise.
2. For Automatic Drain models: Flexible tubing (3/16" ID) may be installed on the Drain Stem to remove discharges. Turn Drain Knob counter-clockwise until it stops, push up to expose the Drain Clip. Remove Drain Clip and Drain Knob, and push tubing onto Drain Stem. The drain may be adjusted to compensate for differing operating conditions by adjusting the Drain Knob. For low flow or low pressure drop, turn the Drain Knob until the drain just closes. For high flows or high pressure drop, turn the Drain Knob clockwise if reduced drain action is required. Turning the Drain Knob clockwise to the stop puts the drain in a manual shutoff position. Turning the Drain Knob counter-clockwise will manually drain the filter.
3. Replace Coalescent Element when the pressure differential reaches 8 to 10 psid (0.55 to 0.69 bar).

TO CLEAN OR REPAIR:

1. Depressurize and lockout air pressure.
2. Remove Bowl Ring and Bowl Assembly by turning counter-clockwise.
3. Remove Lower Baffle by turning counter-clockwise.
4. The Coalescent Element can now be removed. Do NOT clean elements, they must be replaced.
5. To service Automatic Drain, turn Drain Knob counter-clockwise until it stops. Then push Drain Knob up to expose Drain Clip. Remove Drain Clip and pull off Drain Knob.
6. Remove Drain Nut by turning counter-clockwise. The Automatic Drain can now be removed from Bowl and disassembled.
7. The Automatic Drain and Bowl can now be cleaned with soap and water.
8. When re-assembling, be sure all o-rings are correctly located. Lubricate o-rings with Lithium grease. Torque Drain Nut 5-15 in-lbs. Torque Lower Baffle 50-75 in-lbs. Torque Bowl Ring hand tight.
9. If the Coalescent Filter cannot be repaired by cleaning with soap and water, the parts should be replaced.

Replacement Parts

DESCRIPTION	PART NUMBER
AID Metal Bowl Assembly*	OLD: ABFD114-100 NEW: ABFD114-126
AID Metal Ext. Bowl Assembly*	OLD: ABFD114-100H NEW: ABFD114-126H
Manual Metal Bowl Assembly*	OLD: ABF114-100 NEW: ABF114-126
Manual Metal Ext. Bowl Assembly*	OLD: ABF114-100H NEW: ABF114-126H

*Review Bowl Styles on Next Page.

DESCRIPTION	PART NUMBER
Element Kit - 0.3µm	A114-112
Ext. Bowl Element Kit - 0.3µm	A114-113
Element Kit - 0.01µm	A114-112E8
Ext. Bowl Element Kit - 0.01µm	A114-113E8
Automatic Drain Kit	D380
Manual Draincock	103-51SP
Differential Pressure Gauge	106-35



BFCD201 Installation and Maintenance

MASTER PNEUMATIC - DETROIT, INC.

6701 -18 Mile Rd. | Sterling Heights, MI 48314 | Phone: (586) 254-1000 | Fax: (586) 254-6055 | Email: mp@masterpneumatic.com

Parts Listing

KEY	DESCRIPTION
1	Differential Pressure Gauge
2	Head
3	Stud
4	Bowl Ring
5	O-Ring
6	Coalescent Element
7	Metal Bowl
8	Lower Baffle
9	Automatic Drain
10	Drain Nut
11	Drain Knob
12	Drain Clip
13	Manual Draincock

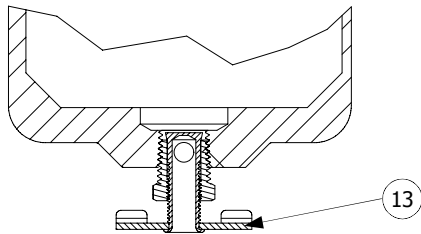
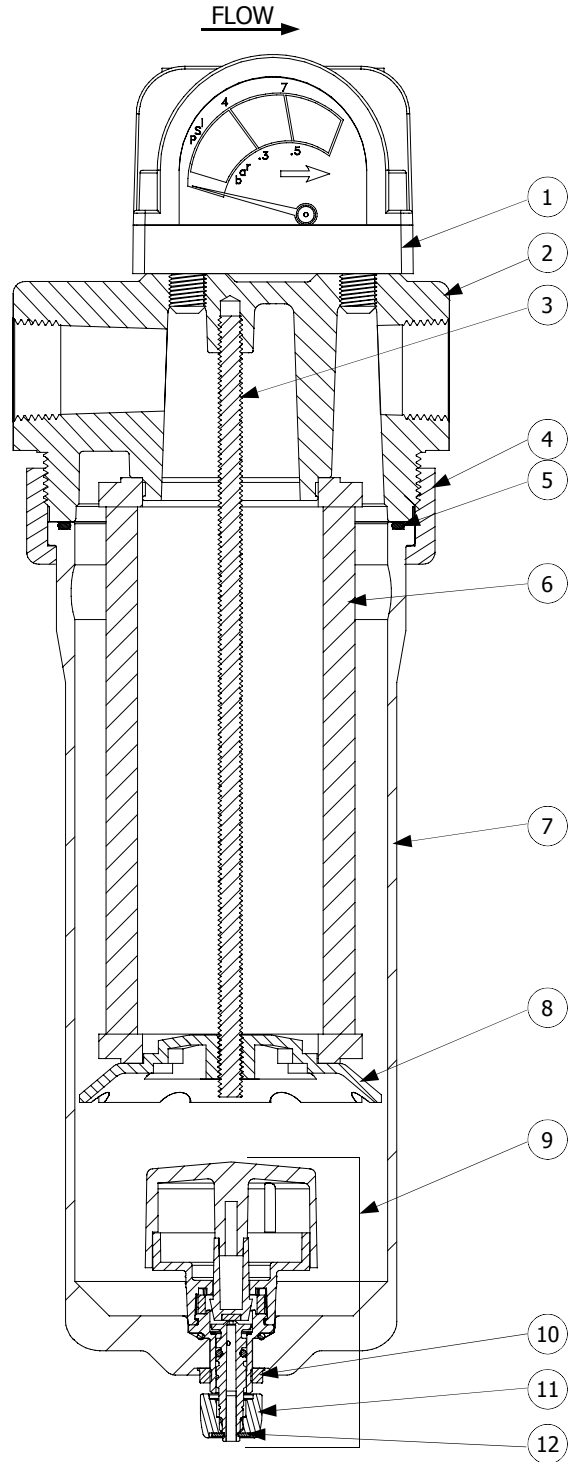

BOWL STYLES

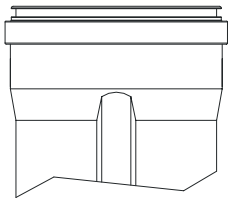

Old Style Bowl

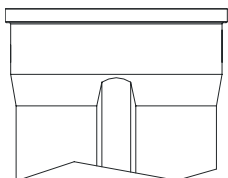

New Style Bowl