



BL237D Installation and Maintenance

MASTER PNEUMATIC - DETROIT, INC.

6701 -18 Mile Rd. | Sterling Heights, MI 48314 | Phone: (586) 254-1000 | Fax: (586) 254-6055 | Email: mp@masterpneumatic.com

PRODUCT NUMBERS:

BL237D-10
BL237D-12

THANK YOU!

You have just purchased a quality Lubricator from Master Pneumatic.

With care in its installation and maintenance, you can expect it to have a long and economical service life. Before you go any further, please take a few minutes to look over this information, then save it for future reference and for the useful service information it contains.

Installation & Operation Procedures

INSTALLATION:

1. Depressurize and lockout air pressure.
2. Upstream pipes must be free of excessive dirt and liquids.
3. Install the Lubricator as near as possible to the device it is to serve.
4. Install the Lubricator so that air flows from inlet to outlet as shown on the head.
5. The Lubricator must be installed vertically with Draincock at the bottom.
6. Lubricators should be installed downstream of any Filters or Regulators in the airline.

OPERATION:

1. To fill Lubricator with Oil, depressurize and lockout air pressure. Either remove Fill Plug or Bowl Assembly to add lubricant. Use Light Spindle Oil 80-120 SSU at 100F. Do not use compound oils containing graphite's, soap fillers, etc.
2. With air pressure on, the oil feed rate can be changed by turning the Adjusting Knob. Turn clockwise for less oil, or counter-clockwise to increase oil delivery. The Sight Dome is used to monitor the oil feed rate (drops/min. etc.). Removal of Adjusting Knob will make the Lubricator tamper resistant.

TO CLEAN OR REPAIR:

1. Depressurize and lockout air pressure.
2. If needed, the Fill Plug can be removed by turning counter-clockwise and cleaned.
3. Remove Bowl Ring and Bowl Assembly by turning counter-clockwise.
4. Both the Bowl Ring and Bowl Assembly can be cleaned.
5. If needed, the Cartridge Assembly can be removed by unscrewing the four Screws and replaced. When replacing the Cartridge Assembly, hand start the screw. This will ensure that the self-tapping screw use the original threads.
6. When re-assembling, be sure all seals are correctly located. Torque Bowl Ring hand tight.
7. If the Lubricator cannot be repaired by cleaning with soap and water, the parts should be replaced.

Replacement Parts

Replacement Bowls List

DESCRIPTION	PART NUMBER
Metal Bowl Assembly*	OLD: ABL237-100 NEW: ABL237-105
Extended Metal Bowl Assembly*	OLD: ABL237-100H NEW: ABL237-105H

*Review Bowl Styles on Next Page.

Replacement Kits List

DESCRIPTION	PART NUMBER
Fill Plug Kit	A28-18
Cartridge Kit	A29-20

Replacement Drain List

DESCRIPTION	PART NUMBER
Manual Draincock	103-51SP



BL237D Installation and Maintenance

MASTER PNEUMATIC - DETROIT, INC.

6701 -18 Mile Rd. | Sterling Heights, MI 48314 | Phone: (586) 254-1000 | Fax: (586) 254-6055 | Email: mp@masterpneumatic.com

Parts Listing

KEY	DESCRIPTION
1	Adjusting Knob
2	Sight Dome
3	Fill Plug
4	O-Ring
5	Cartridge Assembly
6	Screw
7	Head
8	O-Ring
9	Bowl Ring
10	Feed Tube
11	Metal Bowl
12	Manual Draincock

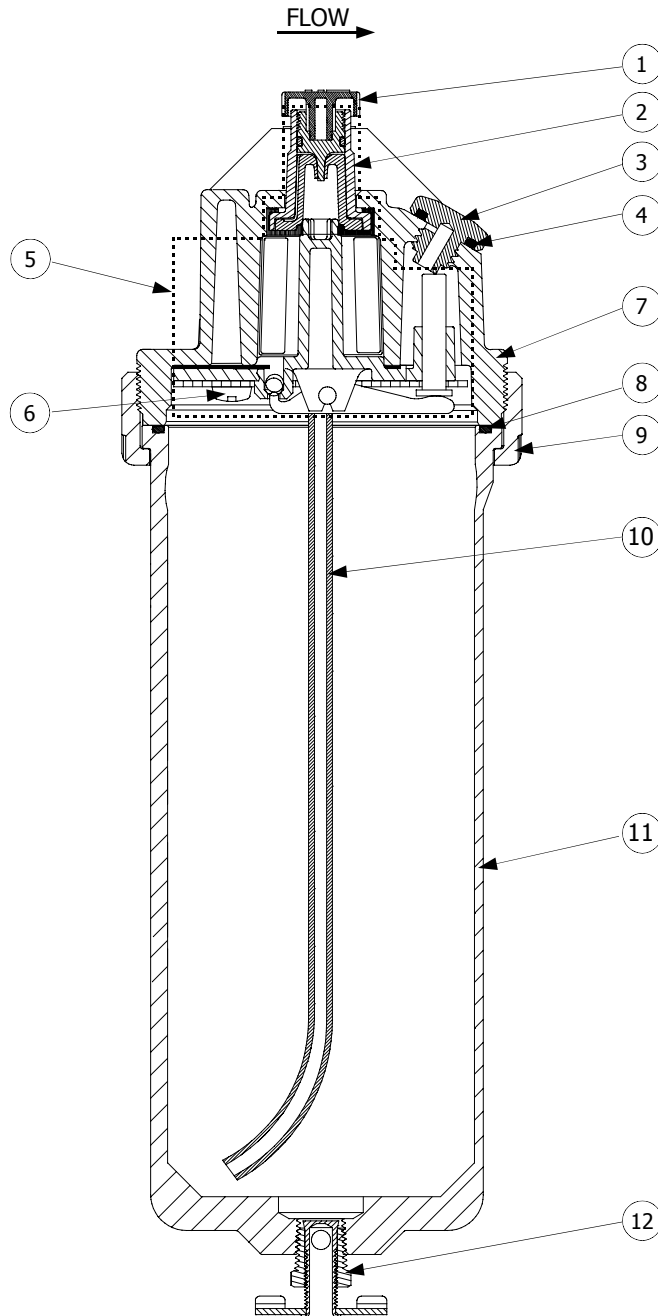

BOWL STYLES

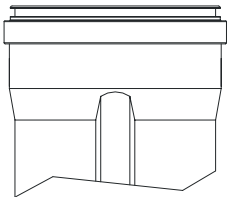

Old Style Bowl

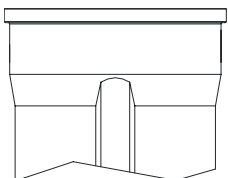

New Style Bowl